

# Model **AT1300/4300**

• **Industrial Maintenance** • **Broadcast** • **Construction** • **Agriculture** • **Grounds Maintenance**

## Model AT1300

- Removable direct crank rewind reel.
- Adjustable cam-lock drag brake.
- 3-conductor, 45-amp collector ring is standard.
- 6 foot power source lead of 10/3 cable.
- 15-amp, 3-prong straight blade (optional twist lock is available).
- Additional conductors available; consult factory.
- Direct offset rewind crank.

**Model AT1300**



## Aluminum Hand Truck

### Model 4300-AL

Part No. 9906.0795

#### For portability of hose and cable reels.

- Large pneumatic tires.
- Reel permanently attached.
- Overall dimensions will vary according to the reel model used.
- Hand truck, axle, and wheels shipped separately for customer installation. Specify if reel axis is perpendicular or parallel to truck axle.



**Assembled 4300-AL truck with reel attached**

## PARTS DRAWING – ISO 189

Model Number	Cable Capacity of Reel feet m				Approx. Weight lb. kg		Reel Dimensions in. mm							
	Ga./No. of Conductors						NET	SHIP	A	B	C	D	E	F
	O.D. in. mm	14/3	12/3	10/3										
<b>AT1300</b>	.53	.60	.69		<b>70</b>	<b>102</b>	<b>25.88</b>	<b>12</b>	<b>6</b>	<b>22.62</b>	<b>16.5</b>	<b>32.5</b>	<b>42.5</b>	<b>14.38</b>
	14	15	18		32	46	657	305	152	575	419	825	1080	365

### Notes:

1. Specifications subject to change.
2. Hand truck is also sold separately.  
Maximum reel size dimensions when installed on hand truck:  
A=32" (812.8 mm), B=27" (685.8 mm), E=32" (812.8 mm).
3. **Be sure to check dimensions and weights prior to ordering.**

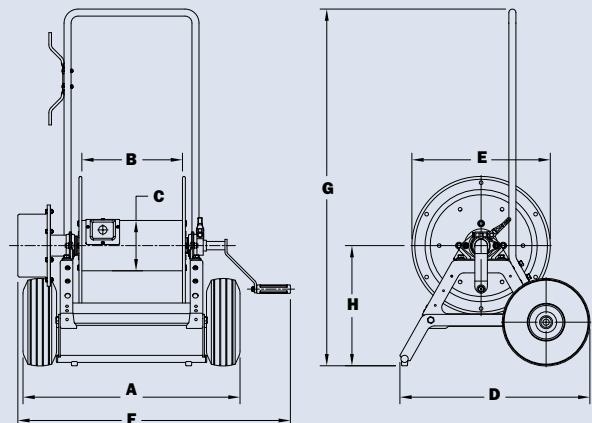

Model AT1300